

# DRX200, DRX750 and DRX1500 Models

---

## Installation, Operation and Maintenance Manual

---



# DRX™ Impact Beds

---

Purchase Date: \_\_\_\_\_

Purchased From: \_\_\_\_\_

Installation Date: \_\_\_\_\_

This information will be helpful for any future inquiries or questions about replacement parts, specifications or troubleshooting.

# Table of Contents

---

<b>Section 1 - Important Information .....</b>	<b>2</b>
1.1 General Introduction .....	2
1.2 User Benefits .....	2
1.3 Proper Impact Bed Selection .....	3
1.4 Selecting the Right Impact Bar .....	4
1.5 Installation and Service Option.....	4
1.6 DRX Impact Bed Spec Sheet.....	5
<b>Section 2 - Safety Considerations and Precautions .....</b>	<b>6</b>
2.1 Stationary Conveyors.....	6
2.2 Operating Conveyors.....	6
<b>Section 3 - Pre-Installation Checks and Options.....</b>	<b>7</b>
3.1 Checklist.....	7
3.2 Optional Installation Accessories.....	8
<b>Section 4 - Installation Instructions.....</b>	<b>9</b>
<b>Section 5 - Pre-Operation Checklist and Testing.....</b>	<b>13</b>
5.1 Pre-Op Checklist.....	13
5.2 Test Run the Conveyor .....	13
<b>Section 6 - Maintenance.....</b>	<b>14</b>
6.1 New Installation Inspection.....	14
6.2 Routine Visual Inspection.....	14
6.3 Routine Physical Inspection .....	14
6.4 Impact Bar Replacement Instructions.....	15
6.5 Maintenance Log.....	17
6.6 Impact Bed Maintenance Checklist.....	18
<b>Section 7 - Troubleshooting .....</b>	<b>19</b>
<b>Section 8 - Specs and CAD Drawings.....</b>	<b>20</b>
8.1 Specifications and Guidelines.....	20
8.2 CAD Drawings .....	21
<b>Section 9 - Replacement Parts .....</b>	<b>27</b>
9.1 Replacement Parts List .....	27
9.2 Optional Replacement Parts.....	28
<b>Section 10 - Other Flexco Conveyor Products.....</b>	<b>29</b>

# Section 1 - Important Information

---

## 1.1 General Introduction

We at Flexco are very pleased that you have selected a DRX™ Impact Bed for your conveyor system.

This manual will help you to understand the operation of this product and assist you in making it work up to its maximum efficiency over its lifetime of service.

It is essential for safe and efficient operation that the information and guidelines presented be properly understood and implemented. This manual will provide safety precautions, installation instructions, maintenance procedures and troubleshooting tips.

If, however, you have any questions or problems that are not covered, please visit our web site or contact our Customer Service Department:

**Web site: Flexco.com**

**Customer Service: Australia: 61-2-8818-2000**

**Chile: 56-2-8967870 • China: 86-21-33528388 • England: 44-1274-600-942**

**Germany: 49-7428-9406-0 • India: 91-44-4354-2091 • Mexico: 52-55-5674-5326**

**Singapore: 65-6281-7278 • South Africa: 27-11-608-4180 • USA: 1-800-541-8028**

Please read this manual thoroughly and pass it on to any others who will be directly responsible for installation, operation and maintenance of this cleaner. While we have tried to make the installation and service tasks as easy and simple as possible, **it does however require correct installation and regular inspections and adjustments to maintain top working condition.**

## 1.2 User Benefits

The “transfer point” is integrally important to the successful operation of a belt conveyor system. The material transferred from one conveyor (or other source) to another conveyor must be done without damaging the conveyor’s key component...the belt. A correctly-selected impact bed is critical for this task.

Since material size, weight and the drop height can cause considerable impact force that can damage the belt, the right impact bed must be chosen to absorb the impact energy and minimize any damage to the beltline.

The proper impact bed can also support the belt in the loading zone to prevent material spillage.

The DRX Impact Beds offer these features and benefits:

- Extra Belt Protection - DRX means “Dual Relief Xtra”. Our beds offer our exclusive Velocity Reduction Technology™, which means two levels of force reduction to absorb more impact energy and minimize transmission back to the belt. The impact bars are properly supported for one level of defense and unique Impact Energy Absorbers provide the second level of impact relief. The results: less belt damage and less rebounding and degradation of the materials.

# Section 1 - Important Information

- Easy Maintenance - Our Slide-Out Service™ is quick, safe and convenient. Each bed separates in the middle and the two sides slide apart. This provides easy access to all of the impact bars for replacement.
- Cost Effective - Each bed is constructed with steel channel crossbeams for long service life; and low-cost square washers and carriage bolts replace traditional, expensive T-bolts for securing the impact bars.

## 1.3 Proper Impact Bed Selection

DRX impact beds are expressly designed to absorb energy from falling materials. The bed model should be spec'd to the needs of the conveyor application. To do this, the following data points are needed (Also see the DRX Impact Bed Spec Sheet on Page 5).

1. **Belt Width** - This is typically a simple check and the only additional information that would be required is if belt width is inconsistent with structure width.
2. **Troughing Angle** - What is the angle of the current bed or troughing set?
3. **Roller Diameter and CEMA Rating** - Rollers are typically 125mm or 150mm and rated CEMA C, D or E.
4. **Bed Length** - Typically 4' (1.2M) or 5' (1.5M). Special lengths available upon request.
5. **Drop Height and Lump Size & Weight** - This is the critical information required.
  - a. Drop Height - The measurement from where the material leaves the feeding conveyor to where it makes contact with the receiving conveyor.
  - b. Lump Size and Weight - The lump size - The largest dimension of the material pieces dropping. The material weight is of the largest lump size found and weighed.
  - c. Chart for Rough Calculations - Weighing is always more accurate, but the chart values will give a rough weight estimate.

	Bituminous Coal (weight in kilograms)	Limestone (weight in kilograms)	Aggregate (weight in kilograms)	Granite (weight in kilograms)	Iron Ore (weight in kilograms)	Platinum Ore (weight in kilograms)
Lump Size	Density = 1362 kg/m <sup>3</sup>	Density = 2195 kg/m <sup>3</sup>	Density = 2403 kg/m <sup>3</sup>	Density = 2803 kg/m <sup>3</sup>	Density = 4998 kg/m <sup>3</sup>	Density = 16,980 kg/m <sup>3</sup>
100mm	1.09	1.77	1.91	2.22	3.99	13.56
125mm	2.13	3.40	3.76	4.35	7.80	26.49
150mm	3.67	5.90	6.49	7.57	13.47	45.77
200mm	8.71	14.02	15.38	17.92	31.93	108.54
250mm	17.01	27.40	29.98	34.97	62.37	211.96
300mm	29.39	47.36	51.85	60.46	107.82	366.28
350mm	46.63	75.16	82.33	96.03	171.19	581.64
400mm	69.63	112.22	122.88	143.34	255.55	868.22

NOTE: Shale is approximately the same as limestone.

# Section 1 - Important Information

Now you can calculate the impact energy (in kg.-m.) and make the bed selection by the rating chart.

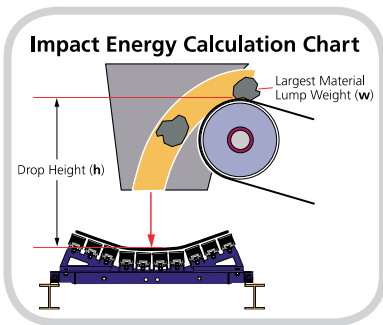

**By using this simple kg-m formula, for whatever your application, you will know the load capacities needed to specify the best Impact Bed to get the job done right.**

**Match kg-m to bed rating:**

0 kg-m.....	DRX200
0-25 kg-m.....	DRX750
25-100 kg-m.....	DRX1500

**Calculate Impact Energy:**

Lump weight \_\_\_\_\_ kg

x Drop length \_\_\_\_\_ m

---

Total \_\_\_\_\_ kg-m

A sample DRX Impact Bed Spec Sheet is included (Page 5) for future use.

## 1.4 Selecting the Right Impact Bar

The primary purpose of the impact bars is to absorb the energy of the falling material and prevent damage to the belt. They are the first line of defense. Typical impact bars can be purchased with a 13mm UHMW top cover or with a longer-wearing 25mm top cover. Care should be taken to choose the right top cover thickness for your application to ensure maximum energy absorption.

Generally, impact bars are 75mm high and 100mm wide. They are made up of an aluminum extrusion base, an elastomer (rubber) centre, and a low-friction (UHMW) top cover. The extrusion takes up about 25mm of the bar's height. That means that depending on the thickness of the top cover chosen (13 or 25mm), the energy-absorbing rubber core is either 38mm or 25mm. Reducing the rubber core of each bar by 50% in heavier impact applications can reduce the impact bed's effectiveness and performance.

Some general guidelines:

1. The impact bed's primary use is for dust suppression with no sizeable amount of impact (for loads not exceeding 47 kg-m of impact energy), choose the 25mm top cover. It will offer twice the service life with no measurable performance degradation.
2. For applications with 47 kg-m or more of impact force, the 13mm topcover is strongly recommended. It will provide 50% more energy impact protection for the belt.

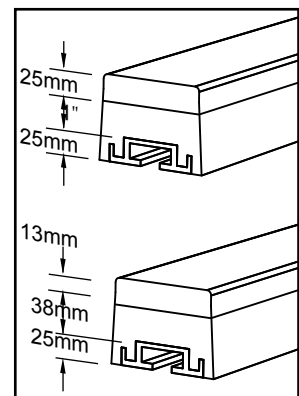

## 1.5 Installation and Service Option

The DRX Impact Bed is designed to be easily installed and serviced by your on-site personnel. However, if you would prefer complete turn-key factory service, please contact your local Flexco Field Engineer or your Flexco Distributor.

# 1.6 DRX Impact Bed Spec Sheet

**CUSTOMER INFO:**

Company Name: \_\_\_\_\_  
 Address: \_\_\_\_\_ Date: \_\_\_\_\_  
 \_\_\_\_\_ Phone # \_\_\_\_\_  
 Contact Name: \_\_\_\_\_ Fax # \_\_\_\_\_  
 Title/Position: \_\_\_\_\_ E-Mail: \_\_\_\_\_

- \_\_\_\_\_ A Mounting bolt center-to-center
- \_\_\_\_\_ B Center roll height above mounting base
- \_\_\_\_\_ C Inside structure dimension
- \_\_\_\_\_ D Trough angle
- \_\_\_\_\_ E Belt width
- \_\_\_\_\_ F Length of load zone
- \_\_\_\_\_ G Material
- \_\_\_\_\_ H Drop Height
- \_\_\_\_\_ I Maximum Lump size
- \_\_\_\_\_ J Tons per Hour
- \_\_\_\_\_ W Maximum Lump weight

- \_\_\_\_\_ Roll Length 1
- \_\_\_\_\_ Roll Length 2
- \_\_\_\_\_ Roll Length 3

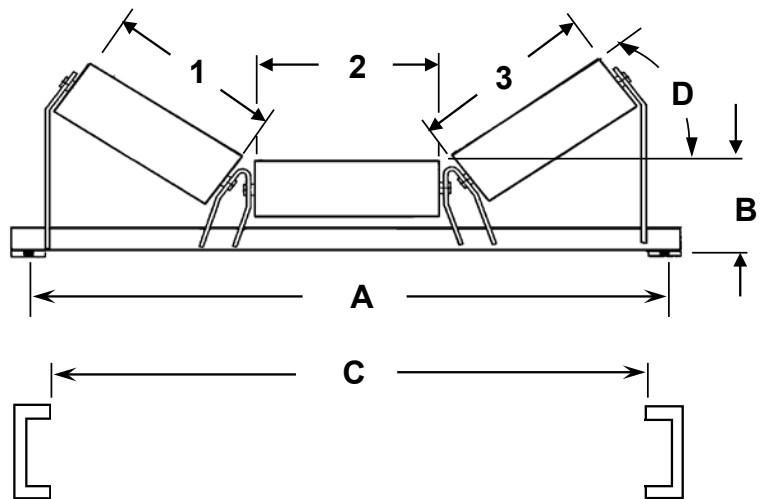

## Impact Energy Calculation Chart

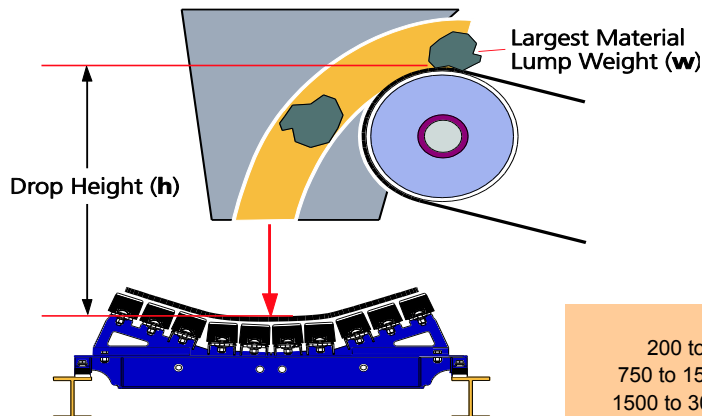

**Impact Energy**

Lump Weight (w) \_\_\_\_\_  
 Drop Height (h) x \_\_\_\_\_  
 Total - lb-ft (kg-m) \_\_\_\_\_

(See Below)

Up to 200 lb-ft (25 kg-m)	<b>DRX200</b>
200 to 750 lb-ft (25 to 100 kg-m)	<b>DRX750</b>
750 to 1500 lb-ft (100 to 200 kg-m)	<b>DRX1500</b>
1500 to 3000 lb-ft (200 to 400 kg-m)	<b>DRX3000</b>

0711 X1929



## Section 2 - Safety Considerations and Precautions

---

Before installing and operating the DRX™ Impact Bed, it is important to review and understand the following safety information.

There are set-up, maintenance and operational activities involving both **stationary** and **operating** conveyors. Each case has a safety protocol.

---

### 2.1 Stationary Conveyors

The following activities are performed on stationary conveyors:

- Installation
- Skirt rubber adjustments
- Impact bar replacement
- Cleaning
- Repairs

#### **DANGER**

It is imperative that Lockout/Tagout (LOTO) regulations, be followed before undertaking the preceding activities. Failure to use LOTO exposes workers to uncontrolled behavior of the impact bed caused by movement of the conveyor belt. Severe injury or death can result.

Before working:

- Lockout/Tagout the conveyor power source
- Disengage any takeups
- Clear the conveyor belt or clamp securely in place

#### **WARNING**

**Use Personal Protective Equipment (PPE):**

- Safety eyewear
- Hardhats
- Safety footwear

Close quarters and heavy components create a worksite that compromises a worker's eyes, feet and skull.

PPE must be worn to control the foreseeable hazards associated with conveyor belt components. Serious injuries can be avoided.

---

### 2.2 Operating Conveyors

There are two routine tasks that must be performed while the conveyor is running:

- Inspection of the sealing performance
- Dynamic troubleshooting

#### **DANGER**

Every belt conveyor is an in-running nip hazard. Never touch or prod an operating impact bed. Conveyor hazards cause instantaneous amputation and entrapment.

#### **WARNING**

Conveyor chutes contain projectile hazards. Stay as far from the impact bed as practical and use safety eyewear and headgear. Missiles can inflict serious injury.

#### **WARNING**

Never adjust anything on an operating impact bed. Unforeseeable materials falling into the chute can cause violent movements of the impact bed structure. Flailing hardware can cause serious injury or death.



## Section 3 - Pre-Installation Checks and Options

---

### 3.1 Checklist

- Check the model and size of the impact bed. Is it the right one for your beltline?
- Check the bed to be sure all the parts are included in the shipment.
- Find the Information Packet in the shipment.
- Review the “Tools Needed” section on the front of the installation instructions.
- Prepare the conveyor site:
  - Lift the belt in the transfer zone. Use a lifting hoist or Flexco’s Belt Lifters.
  - Remove the old impact bed or impact idlers.
  - Inspect the conveyor structure for damage or misalignment. Make adjustments as necessary.
  - Troughing idlers should be installed directly before and after the new impact bed.

## Section 3 - Pre-Installation Checks and Options

### 3.2 Optional Installation Accessories

Optional tools can make the installation of the DRX™ Impact Bed easier and faster.

Flex-Lifter Conveyor Belt Lifter		
Description	Ordering Number	Item Code
Medium Flex-Lifter 900 - 1500 mm	FL-M	76469
Large Flex-Lifter 1200 - 1800 mm	FL-L	76470
XL Flex-Lifter 1800-2400 mm	FL-XL	76983

#### Flex-Lifter™ Conveyor Belt Lifter

The Flexco® Flex-Lifter makes the job of lifting the conveyor belt easy and safe. Using two Flex-Lifters, the belt can be quickly lifted out of the way to install the impact bed. The Flex-Lifter has the highest safe lift rating available at 1800 kg on Medium and Large, and 2725 kg on XL. And it's versatile. It can also be used to lift topside or return side belt for splicing, roller replacement or other maintenance jobs.

Available in three sizes: Medium for belt widths 900 - 1500mm, Large for belt widths 1200 - 1800mm, and XL for belt widths 1800 - 2400mm.

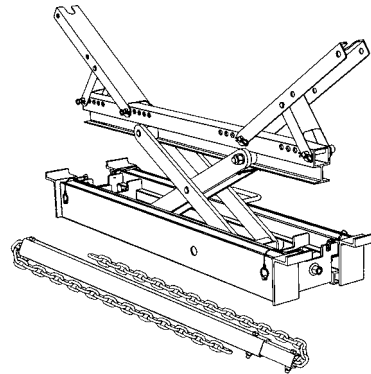

Impact Bed Shim Kits			
Description	Ordering Number	Item Code	Wt. Kgs.
DRX200 Shim Kit	SHIM-KITL	77548	6.2
DRX750 Shim Kit	SHIM-KITM	77549	9.3
DRX1500 Shim Kit	SHIM-KITH	77550	12.3

#### Shims

Depending on your idler rating and size, shimming may be required. See charts below for quantity of kits required.

Shim Chart		
Impact Bed Size	Cema C or D, 125mm IDLERS	CEMA C or D, 150mm IDLERS
DRX200: 600-900mm	Shim idler up 13mm	No Kits Required
DRX200: 1050-1800mm	No Kits Required	Use (1) SHIM-KITL; Shim up 13mm
DRX750: 600-900mm	Shim idler up 13mm)	No Kits Required
DRX750: 1050-1800mm	No Kits Required	Use (1) SHIM-KITM; Shim up 13mm
DRX1500: 600-900mm	Shim idler up 13mm	No Kits Required
DRX1500: 1050-1800mm	No Kits Required	Use (1) SHIM-KITH; Shim up 13mm
DRX3000: 1050-1500mm	Shim idler up 50mm	Shim idler up 13mm
DRX3000: 1800-2400mm	Shim idler up 63mm	Shim idler up 50mm

Impact Bed Handy Wrench			
Description	Ordering Number	Item Code	Wt. Kgs.
Impact Bed Handy Wrench	HW-IMPB	76939	0.7

#### Impact Bed Handy Wrench

A handy ratcheting wrench with two common sizes (19mm and 24mm) for easier installation and maintenance of impact beds.

Shim Chart		
Impact Bed Size	CEMA E, 150mm IDLERS	CEMA E, 175mm IDLERS
DRX200: 900-1500mm	Use (3) SHIM-KITL; Shim up 38mm	Use (4) SHIM-KITL; Shim up 50mm
DRX200: 1800mm	Use (4) SHIM-KITL; Shim up 50mm	Use (5) SHIM-KITL; Shim up 63mm
DRX750: 900-1500mm	Use (3) SHIM-KITM; Shim up 38mm	Use (4) SHIM-KITM; Shim up 50mm
DRX750: 1800mm	Use (4) SHIM-KITM; Shim up 50mm	Use (5) SHIM-KITM; Shim up 63mm
DRX1500: 900-1500mm	Use (3) SHIM-KITH; Shim up 38mm	Use (4) SHIM-KITH; Shim up 50mm
DRX1500: 1800mm	Use (4) SHIM-KITH; Shim up 50mm	Use (5) SHIM-KITH; Shim up 63mm
DRX3000: 1050-1500mm	No Shim Required	No Shim Required
DRX3000: 1800-2400mm	No Shim Required	No Shim Required

# Section 4 - Installation Instructions

## 4.1 DRX Impact Bed

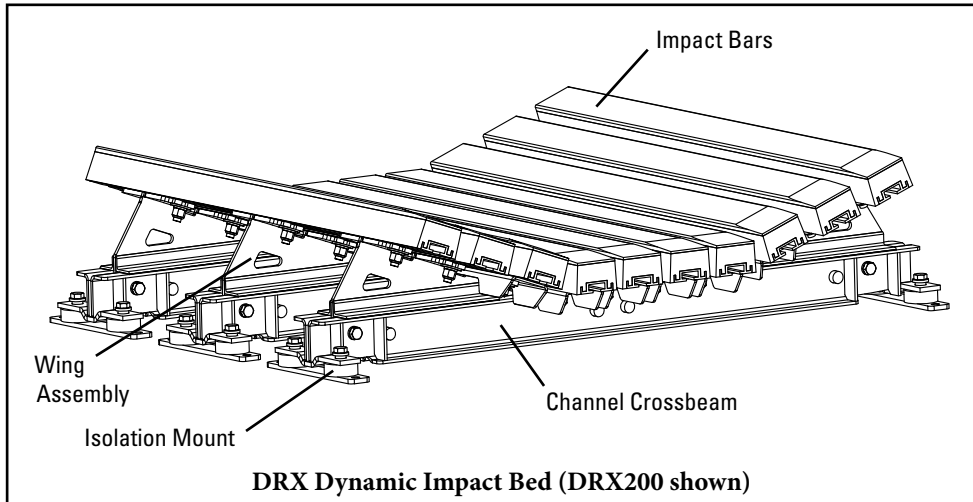

**Physically lock out and tag the conveyor at the power source before you begin installation.**

**Caution:** Components may be heavy. Use safety approved lifting procedures.

**Before Installation:** Inspect structure; confirm CEMA rating. Shim bed or idlers per instructions. **NOTE:** Installation of an idler is required 25-150mm after a Flexco DRX Impact Bed (Fig. 1). (Do not place more than two beds, then add idlers between them.) With both idlers in place, measure the distance from the top of the idler to the structure. Shim as shown in Table 1.

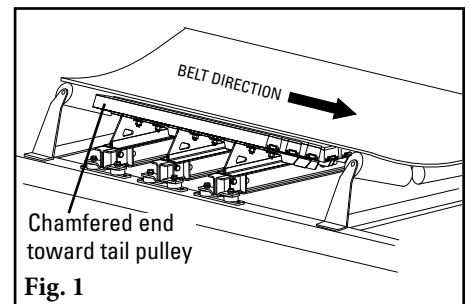

- Tools Needed:**
- 19mm open-ended wrench
  - 19mm drive socket with socket or impact wrench
  - 90° square
  - Come-along
  - Grease Pencil
  - Measuring Tape
  - Cutting torch
  - Flex-Lifter™ (helpful)
  - Welder

**Table 1: Shim Requirements**

Idler Diameter (CEMA C or D)	600-900mm Belt Width	1050-1800mm Belt Width
125 mm	Idler up 13mm	No shim
150 mm	No shim	Bed up 50mm
Idler Diameter (CEMA C or D)	900-1500mm Belt Width	1800mm Belt Width
150 mm	Bed up 38mm	Bed up 50mm
175 mm	Bed up 50mm	Bed up 63mm

- Free the area of previous system.** Remove material (idlers, etc.) from the area of desired installation. Loosen or remove skirting material for extra space. If available, use Flex-Lifters before and after the load zone to lift the belt out of the way.
- Visually locate centre of loading zone.** Determine the centre of the load zone on one side of the structure and mark (Fig. 2).

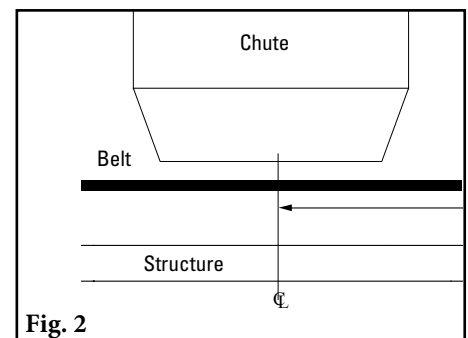

# Section 4 - Installation Instructions

## 4.1 DRX Impact Bed (cont.)

3. **Locate mounting templates.** Measure and mark where the centre of the template will sit on the structure by measuring belt width 225mm and centring this on the structure (Fig. 3a). Lengthwise, centre template over the centre mark from Step 2. Mark and measure from the notch in end of template to a fixed point on the structure, and then transfer this dimension to the opposite side of the structure. Align notches on mounting templates with marks on structure and mark all the holes (Fig. 3b). Drill or torch holes. Included mounting bolts should fit freely through the holes.

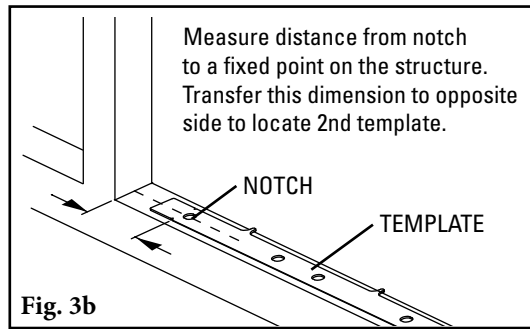
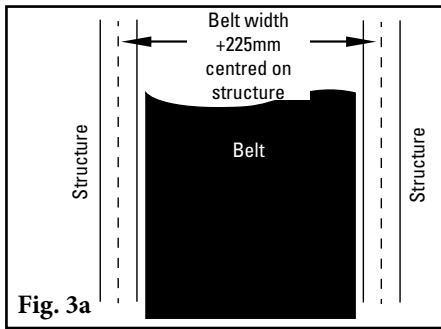

4. **Disassemble wing assemblies.** Remove the centre mounting bolt and the two outer flange bolts. Slide out and remove the wing assembly on each channel crossbeam (Fig. 4).
5. **Install channel crossbeams.** Position all channel crossbeams onto the conveyor structure, aligning with the mounting holes from Step 3. Insert the channel crossbeam mounting bolt and leave finger tight (Fig. 5). Use shims under isolation mounts if needed (see Table 1). Verify height of centre roller on leading and trailing idlers in load zone.

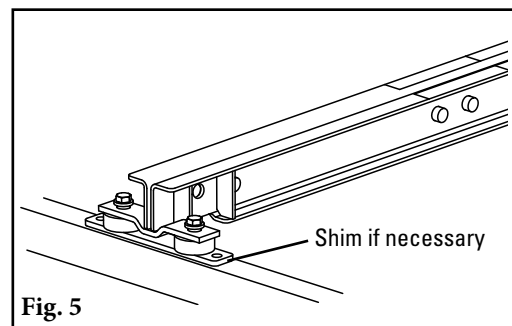
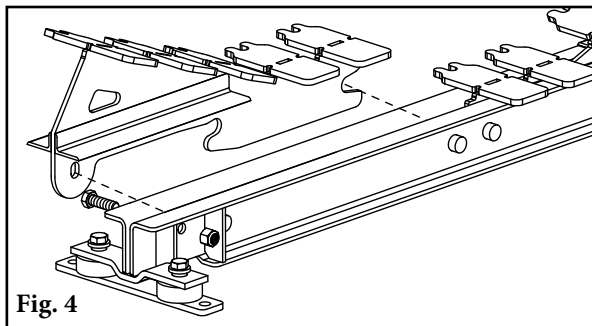

6. **Square up all channel crossbeams.** With a square, ensure the first channel crossbeam is perpendicular to the conveyor structure and tighten in place. Next, space the remaining channel crossbeams with the correct centre-to-centre spacing. Use tabs on provided fixture to set spacing (Fig. 6a). If this is not possible, use dimensions in Table 2 (Fig. 6b). Tighten all bolts in place. **NOTE: Spacing must be exact (+/- 2mm). This step is critical to a successful install.**

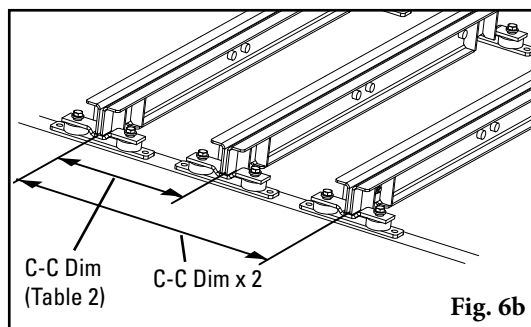
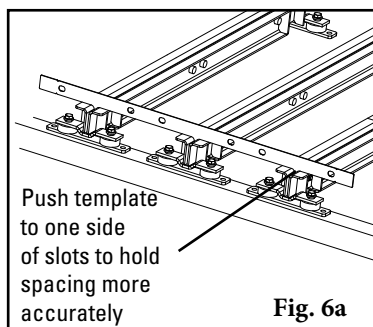
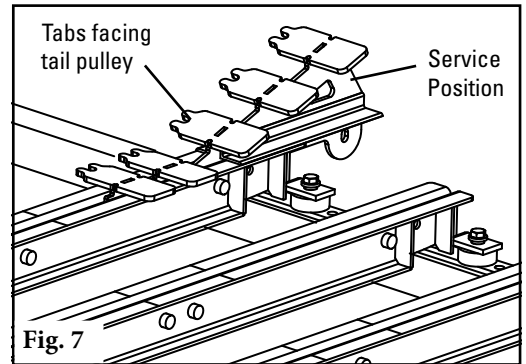

Table 2: Centre-to-Centre (C-C) Dimensions		
	1.2M	5 ft. (1.5M)
DRX200	800mm	1100mm
DRX750	400mm	550mm
DRX1500	312mm	400mm

# Section 4 - Installation Instructions

## 4.1 DRX Impact Bed (cont.)

7. **Install wing assembly into the “service position”.** Slide the wing assembly into the channel crossbeams with the tabs facing the tail pulley (Fig. 7). Slide over the welded pin and pull back to engage. This is called the “service position.



8. **Install impact bars.** Starting with the centre bars first, place the impact bar in place. Position studs between the tabs in the wing assembly while confirming the chamfer of the impact bar is positioned at the tail pulley end of the bed (Fig. 8). **NOTE:** DRX200 has bar supports under centre bars. DRX750 has bar supports under centre bars and first outboard bar on each side. DRX1500 has bar supports under all bars. See below for bar support pattern.

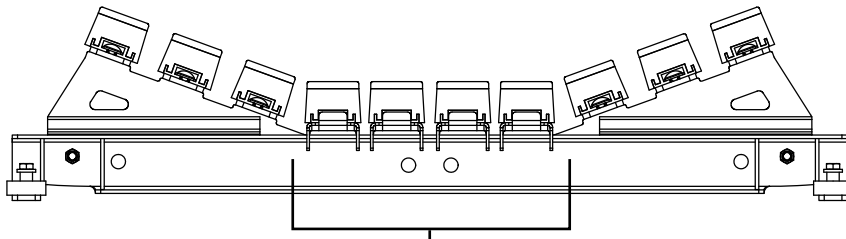
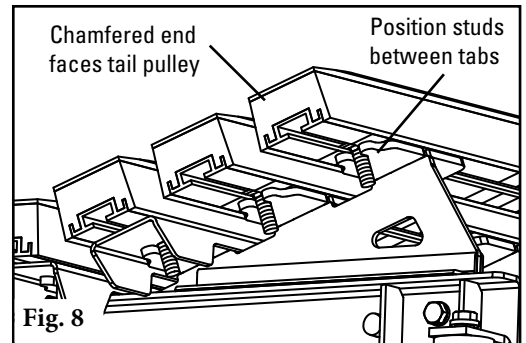

DRX200 has bar supports under centre bars.

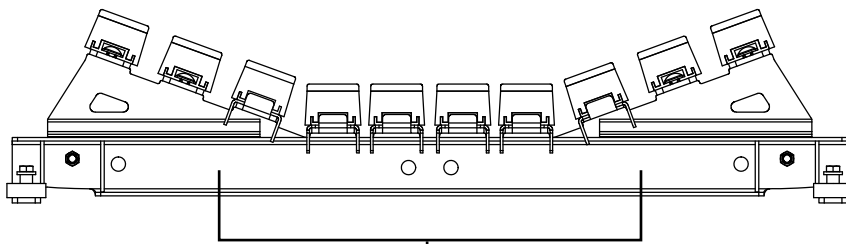

DRX750 has bar supports under centre bars and first outboard bar on each side.

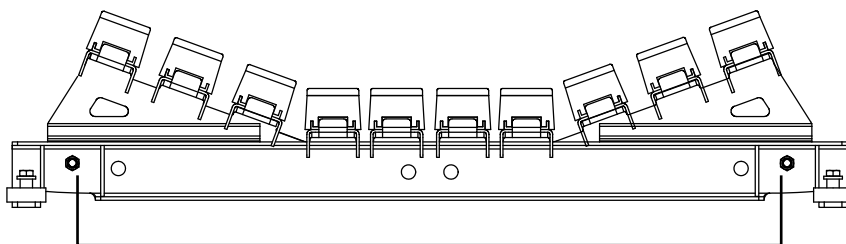

DRX1500 has bar supports under all bars.

## Section 4 - Installation Instructions

### 4.1 DRX Impact Bed (cont.)

9. **Fasten all impact bars.** With all impact bars correctly positioned on the wing assemblies, install on each stud a flat washer, lock washer and a nylock nut. Tighten to 750 m-kg torque.

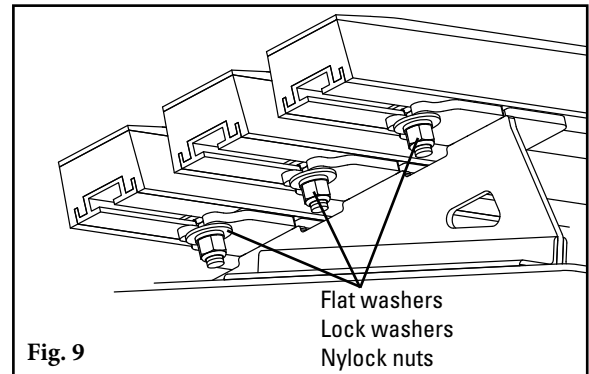

10. **Move wing assemblies into operating position.** Slide the complete side assembly back and forth on the crossbeams to ensure that there is no binding. If there is binding, repeat Step 6. Slide in until the outer mounting holes of the wing assembly align with the inner mounting holes of the cross stringer. A come-along may be necessary for the last inch to line up the mounting holes. Reinsert the centre retaining bolt in each wing assembly and tighten to 750 m-kg torque.

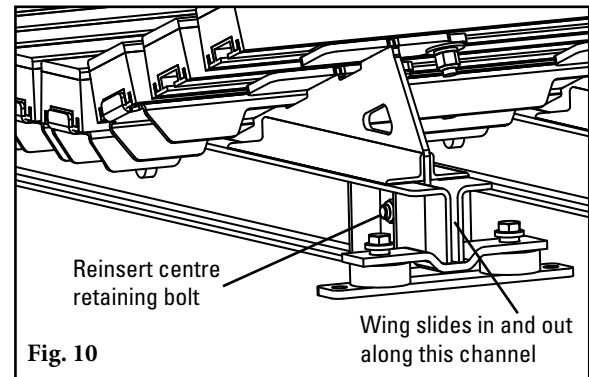

11. **Confirm correct clearance between chute and belt.** Measure distance between top of nearest centre roller and top of centre impact bars. Confirm bars are 13mm below rollers. Readjust skirt rubber to maintain a good seal against impact bed. Replace all protective guarding around load zone.

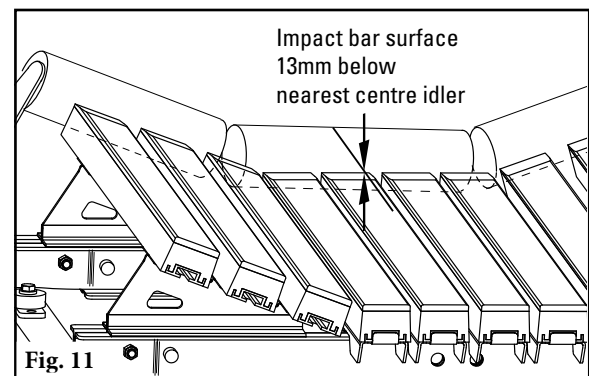

## Section 5 - Pre-Operation Checklist and Testing

---

### 5.1 Pre-Op Checklist

- Recheck that all fasteners are tight
- Check that empty belt is 13mm above the impact bars
- Apply all supplied labels
- Be sure that all installation materials and tools have been removed from the belt and conveyor area

### 5.2 Test Run the Conveyor

- Run the conveyor for at least 15 minutes and confirm the skirt rubber is properly sealing the transfer point. Adjust skirt rubber as needed.

## Section 6 - Maintenance

---

Flexco impact beds are designed to operate with minimum maintenance. However, to maintain superior performance some service is required. When the impact bed is installed a regular maintenance program should be set up. This program will ensure that the impact bed operates at optimal efficiency, and problems can be identified and fixed before any damage is done to the belt, the bed, other conveyor components, or structure.

All safety procedures for inspection of equipment (stationary or operating) must be observed. The DRX Impact Bed operates in the loading zone of the conveyor system and is in direct contact with the moving belt. Only visual observations can be made while the belt is running. Service tasks can be done only with the conveyor stopped and by observing the correct lockout/tagout procedures.

### 6.1 New Installation Inspection

After the impact bed has run for a few days a visual inspection should be made to ensure the bed is performing properly. Make adjustments as needed.

### 6.2 Routine Visual Inspection (every 2-4 weeks)

A visual inspection of the impact bed can determine:

- If the skirt rubber is adequately keeping the chute area sealed
- If the impact bars are worn out and need to be replaced
- If there are excessive materials building up around the impact bed
- If there is damage to the impact bed, belt or other conveyor components

If any of the above conditions exist, a determination should be made on when the conveyor can be stopped for cleaner maintenance.

### 6.3 Routine Physical Inspection (every 6-8 weeks)

When the conveyor is not in operation and properly locked and tagged out, a physical inspection of the cleaner to perform the following tasks:

- Clean material buildup off the impact bed and conveyor structure.
- Closely inspect each impact bar for wear and damage. Replace if needed.
- Check the impact bed frame for damage.
- Inspect all fasteners for tightness and wear. Tighten or replace as needed.
- Inspect skirt rubber and adjust as needed to compensate for impact bar wear.
- When maintenance tasks are completed, test run the conveyor to ensure the impact bed is performing properly.



## Section 6 - Maintenance

### 6.4 Impact Bar Replacement Instructions

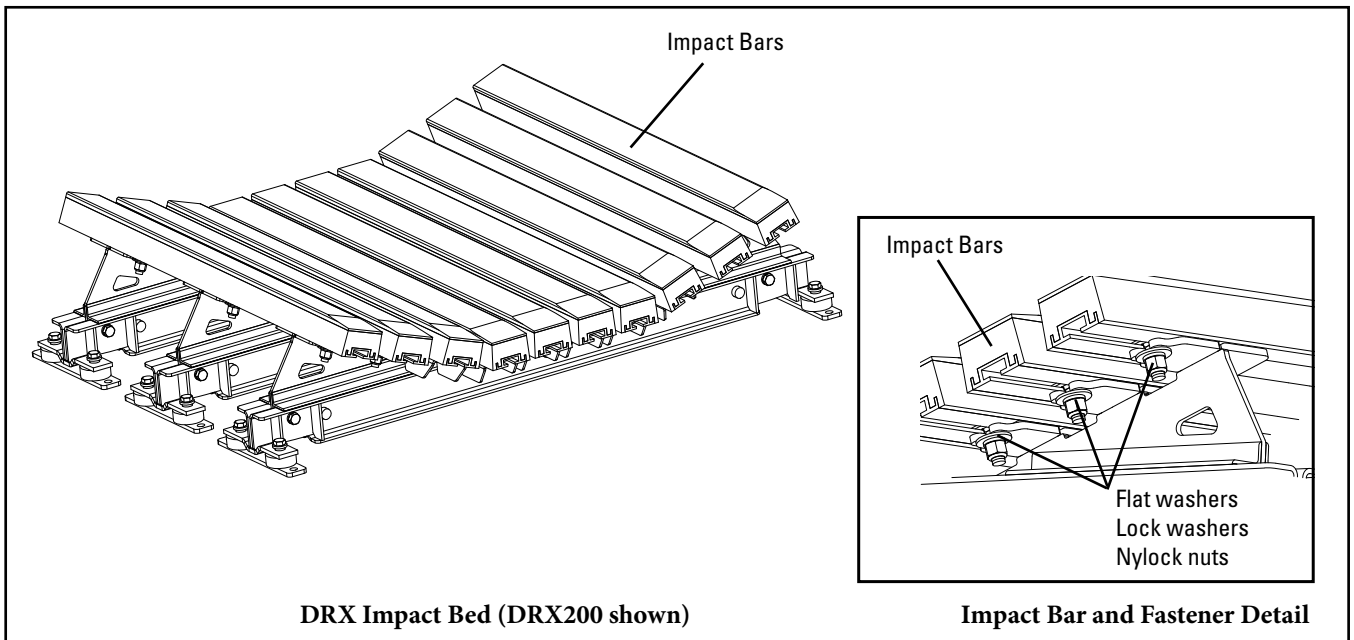

***Physically lock out and tag the conveyor at the power source before you begin maintenance.***

#### Tools Needed:

- (2) 24 mm wrenches or crescent wrenches
- Broom, wire brush and/or putty knife (for cleaning bed and structure)
- Come-along

1. **Remove tension.** Use a Flexco Belt Lifter or other appropriate lifting equipment to lift the belt off the impact bed.
2. **Loosen bed halves.** Remove bolt from each side of each cross-stringer (Fig. 2).
3. **Slide each half of bed out.** Pull out half of the bed on each side until they engage the slide stop (Fig. 3). This may require a come-along to break it free.
4. **Inspect bars.** Check to see which bars are worn or damaged and need to be replaced.

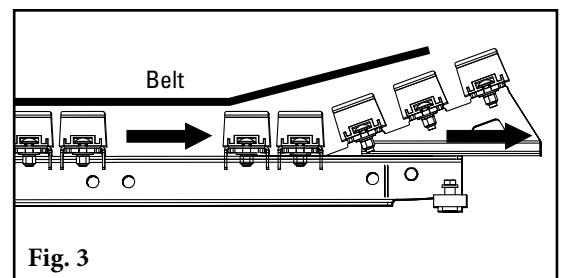
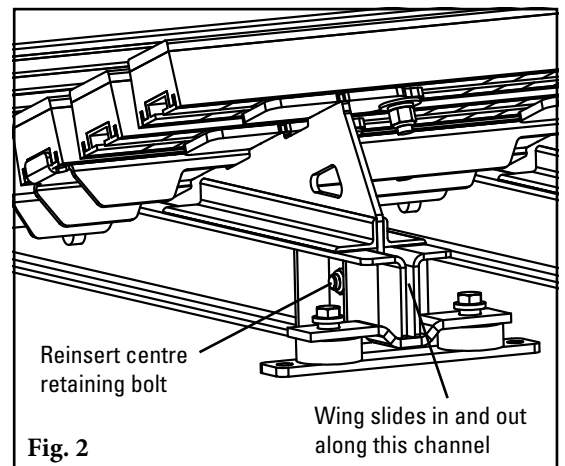

## Section 6 - Maintenance

### 6.4 Impact Bar Replacement Instructions (cont.)

5. **Remove worn bars.** Loosen and remove nuts at each cross stringer and remove the impact bar and bar support, if present (Fig. 5).
6. **Remove support bar if attached.** Remove the nuts holding the support in place and attach to the new impact bar (Fig. 6).
7. **Install new bar and support onto the bed.** Place the new impact bar and bar support onto the bed with the chamfered end facing the tail pulley (Fig. 7). Line up the bolts and tighten the bars to the cross stringers.
8. **Slide bed half back to centre.** Push the bed half back into the bed until the holes in the wing plates and the cross-stringers line up (Fig. 8). **NOTE:** If the holes do not line up, a come-along may need to be used to pull from the opposite side of the bed until the holes are in line. Reinstall bolts and tighten.

**Test run the conveyor.** Run the conveyor for a few minutes and inspect to ensure that the bed is performing properly. Make adjustments as necessary.

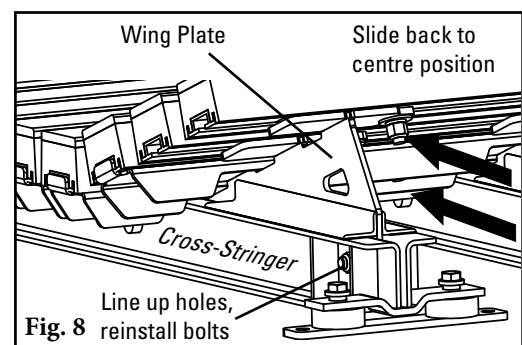
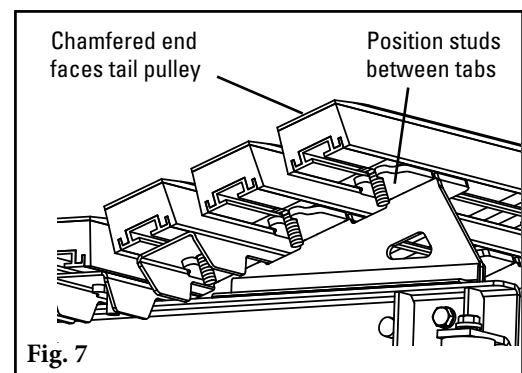
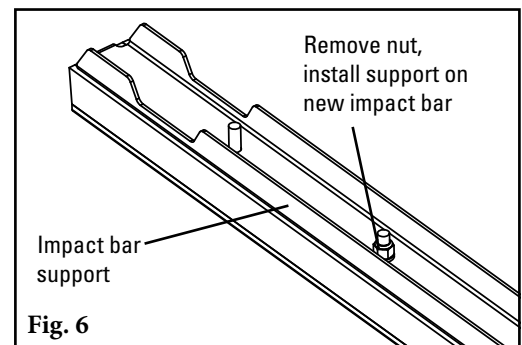
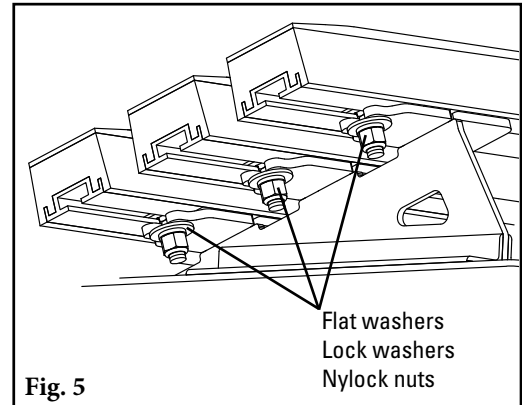

# Section 6 - Maintenance

---

## 6.5 Maintenance Log

Conveyor Name/No. \_\_\_\_\_

Date: \_\_\_\_\_ Work done by: \_\_\_\_\_ Service Quote # \_\_\_\_\_

Activity: \_\_\_\_\_

---

Date: \_\_\_\_\_ Work done by: \_\_\_\_\_ Service Quote # \_\_\_\_\_

Activity: \_\_\_\_\_

---

Date: \_\_\_\_\_ Work done by: \_\_\_\_\_ Service Quote # \_\_\_\_\_

Activity: \_\_\_\_\_

---

Date: \_\_\_\_\_ Work done by: \_\_\_\_\_ Service Quote # \_\_\_\_\_

Activity: \_\_\_\_\_

---

Date: \_\_\_\_\_ Work done by: \_\_\_\_\_ Service Quote # \_\_\_\_\_

Activity: \_\_\_\_\_

---

Date: \_\_\_\_\_ Work done by: \_\_\_\_\_ Service Quote # \_\_\_\_\_

Activity: \_\_\_\_\_

---

Date: \_\_\_\_\_ Work done by: \_\_\_\_\_ Service Quote # \_\_\_\_\_

Activity: \_\_\_\_\_

---



## Section 6 - Maintenance

---

### 6.6 Impact Bed Maintenance Checklist

**DRX Impact Bed:** \_\_\_\_\_ **Serial Number:** \_\_\_\_\_

**Beltline Information:**

Beltline Number: \_\_\_\_\_ Belt Condition: \_\_\_\_\_

Belt Width:  600mm  750mm  900mm  1050mm  1200mm  1350mm  1500mm  1800mm

Transition Distance (back of bed to centre of tail pulley): \_\_\_\_\_ Belt Speed \_\_\_\_\_ Belt Thickness \_\_\_\_\_

Distance to Leading Idler: \_\_\_\_\_ Distance to Trailing Idler: \_\_\_\_\_

Vertical Distance between top of nearest idler and top surface of centre impact bars: \_\_\_\_\_

**Impact Bar Life:**

Date bars installed: \_\_\_\_\_ Date bars inspected: \_\_\_\_\_ Estimated bar life: \_\_\_\_\_

Bar condition: \_\_\_\_\_ inches of top cover remaining

**Impact Bed Frame Condition:**

Good  Bent  Rusted

**Overall Impact Bed Performance:** (Rate the following 1 - 5; 1=very poor, 5=very good)

Appearance: \_\_\_\_\_ Comments: \_\_\_\_\_

Location: \_\_\_\_\_ Comments: \_\_\_\_\_

Maintenance: \_\_\_\_\_ Comments: \_\_\_\_\_

Performance: \_\_\_\_\_ Comments: \_\_\_\_\_

**Other Comments:** \_\_\_\_\_

\_\_\_\_\_

\_\_\_\_\_

\_\_\_\_\_

## Section 7 - Troubleshooting

<b>Problem</b>	<b>Possible Cause</b>	<b>Possible Solutions</b>
Bars wearing out too fast	Impact bars are not at 1/2" below leading and trailing idlers	Adjust/shim as needed to correct dimension
	More than two beds in a row without idler between	Add an idler between at least every other bed to lift the belt back up
	Leading idler does not match troughing angle	Correct the angle of the leading idler to match the bed
Vibration or noise	Belt rubbing too hard on UHMW impact bar covers	Verify height of leading/trailing idlers
	Material buildup under bed	Clean up buildup
	Skirt rubber pushing too hard on belt	Adjust skirt rubber
Bars deforming	Larger material than specified is flowing through transition (under-specified bed)	Replace with a heavier-duty version of impact bed or add additional bar supports
Bar damage	Mechanical splice damaging UHMW top covers	Repair, skive or replace splice

For more information on selection and proper usage of impact beds, ask Flexco Customer Service for one or more of the following DRX™ Tech Tips:

- X1945 - DRX Tech-Tip #1      Spec'ing and recommending DRX Impact Beds
- X1946 - DRX Tech-Tip #2      Impact beds vs. slider beds with rollers - Is it just a matter of choice?
- X1947 - DRX Tech-Tip #3      Over-specifying an impact bed isn't a good idea

# Section 8 - Specs and CAD Drawings

## 8.1 Specifications and Guidelines

**Bed Length:** 1.2M and 1.5M

**Troughing Angles:** 20° and 35°

**Bed Specs per lump size and drop height needs:**

(Per Conveyor Equipment Manufacturers Association (CEMA) guidelines)

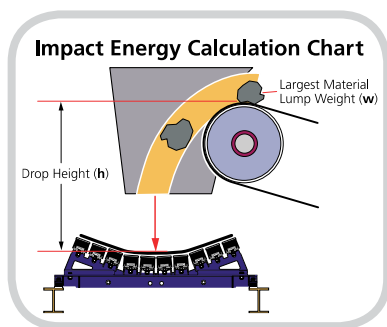

**Impact Energy Calculation:**

Lump weight \_\_\_\_\_ kg  
 x Drop length \_\_\_\_\_ fm  
 -----  
 Total \_\_\_\_\_ kg-m

Up to 0 kg-m ..... DRX200  
 0-25 kg-m ..... DRX750  
 25-100 kg-m ..... DRX1500

Impact Bars per Belt Width (DRX200, 750, 1500)								
Belt Width - in.	24	30	36	42	48	54	60	72
Belt Width - mm	600	750	900	1050	1200	1350	1500	1800
DRX200, 750, 1500	6	6	7	10	10	12	13	14

Impact Bar Supports and Bolt Kits per Belt Width								
Belt Width- in.	24	30	36	42	48	54	60	72
Belt Width- mm	600	750	900	1050	1200	1350	1500	1800
<b>BAR SUPPORTS</b>								
DRX200	2	2	3	4	4	4	5	6
DRX750	4	4	5	6	6	6	7	8
DRX1500	6	6	7	10	10	12	13	14
<b>BOLT KITS</b>								
DRX200	14	14	17	24	24	28	31	34
DRX750	26	26	31	42	42	48	53	58
DRX1500	36	36	42	60	60	72	78	84

# Section 8 - Specifications and CAD Drawings

## 8.2 CAD Drawing - DRX200, 20° Trough

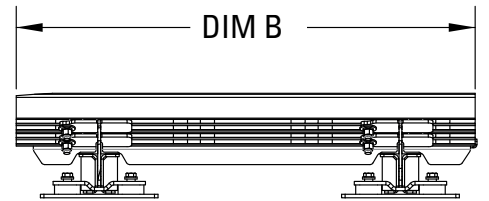
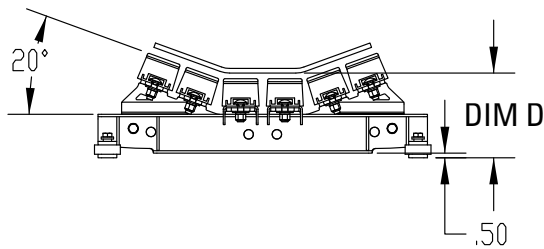
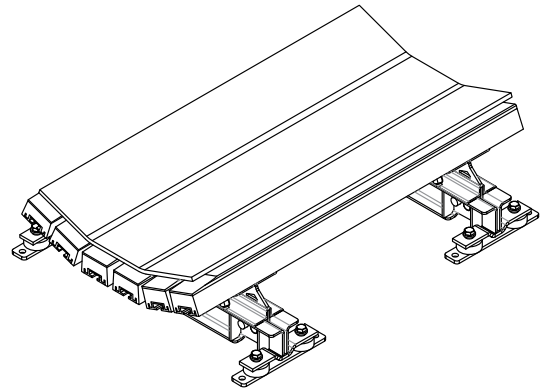
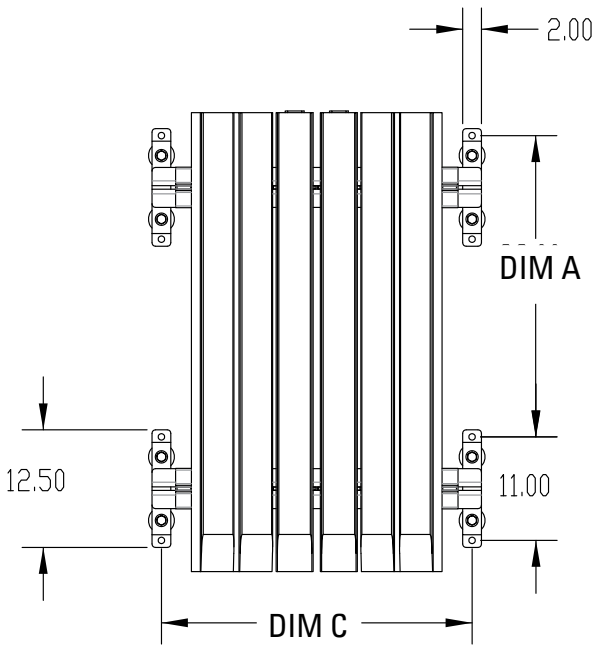

Bed Length	Dim A	Dim B	Bed Width	Dim C	Dim D
4' (1.2M)	32" (800mm)	48.75" (1219mm)	24 (600mm)	33 (835mm)	9 (225)
			30 (750mm)	39 (975mm)	9 (225)
			36 (900mm)	45 (1125mm)	9 (225)
			42 (1050mm)	51 (1275mm)	9 (225)
			48 (1200mm)	57 (1425mm)	9 (225)
			54 (1350mm)	63 (1575mm)	9.25 (231mm)
			60 (1500mm)	69 (1725mm)	9.25 (231mm)
			72 (1800mm)	81 (2025mm)	9.5 (238mm)

Bed Length	Dim A	Dim B	Bed Width	Dim C	Dim D
5' (1.5")	44 (1100mm)	59.06 (1477mm)	24 (600mm)	33 (835mm)	9 (225)
			30 (750mm)	39 (975mm)	9 (225)
			36 (900mm)	45 (1125mm)	9 (225)
			42 (1050mm)	51 (1275mm)	9 (225)
			48 (1200mm)	57 (1425mm)	9 (225)
			54 (1350mm)	63 (1575mm)	9.25 (231mm)
			60 (1500mm)	69 (1725mm)	9.25 (231mm)
			72 (1800mm)	81 (2025mm)	9.5 (238mm)

# Section 8 - Specifications and CAD Drawings

## 8.2 CAD Drawing - DRX200 35° Trough

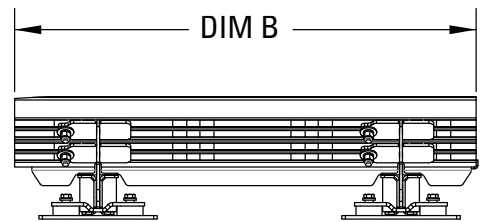
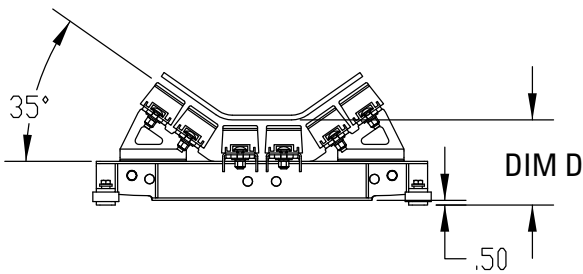
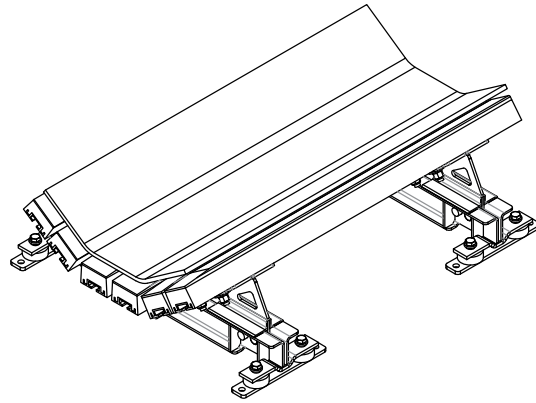
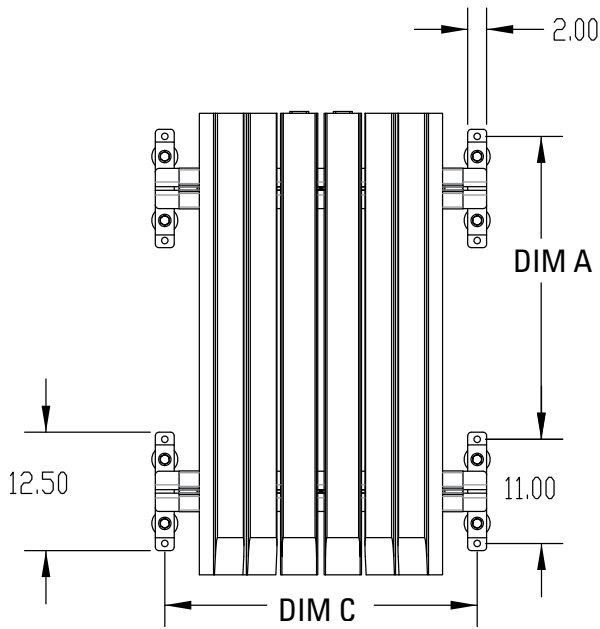

Bed Length	Dim A	Dim B	Bed Width	Dim C	Dim D
4' (1.2M)	32" (800mm)	48.75" (1219mm)	24 (600mm)	33 (835mm)	9 (225)
			30 (750mm)	39 (975mm)	9 (225)
			36 (900mm)	45 (1125mm)	9 (225)
			42 (1050mm)	51 (1275mm)	9 (225)
			48 (1200mm)	57 (1425mm)	9 (225)
			54 (1350mm)	63 (1575mm)	9.25 (231mm)
			60 (1500mm)	69 (1725mm)	9.25 (231mm)
			72 (1800mm)	81 (2025mm)	9.5 (238mm)

Bed Length	Dim A	Dim B	Bed Width	Dim C	Dim D
5' (1.5")	44 (1100mm)	59.06 (1477mm)	24 (600mm)	33 (835mm)	9 (225)
			30 (750mm)	39 (975mm)	9 (225)
			36 (900mm)	45 (1125mm)	9 (225)
			42 (1050mm)	51 (1275mm)	9 (225)
			48 (1200mm)	57 (1425mm)	9 (225)
			54 (1350mm)	63 (1575mm)	9.25 (231mm)
			60 (1500mm)	69 (1725mm)	9.25 (231mm)
			72 (1800mm)	81 (2025mm)	9.5 (238mm)



# Section 8 - Specifications and CAD Drawings

## 8.2 CAD Drawing - DRX750, 20° Trough

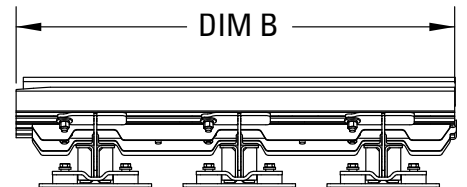
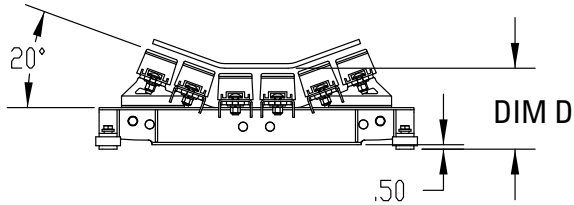
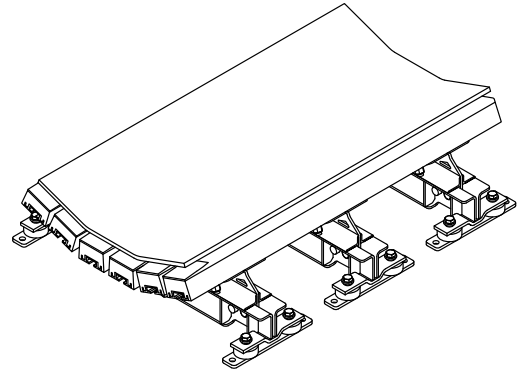
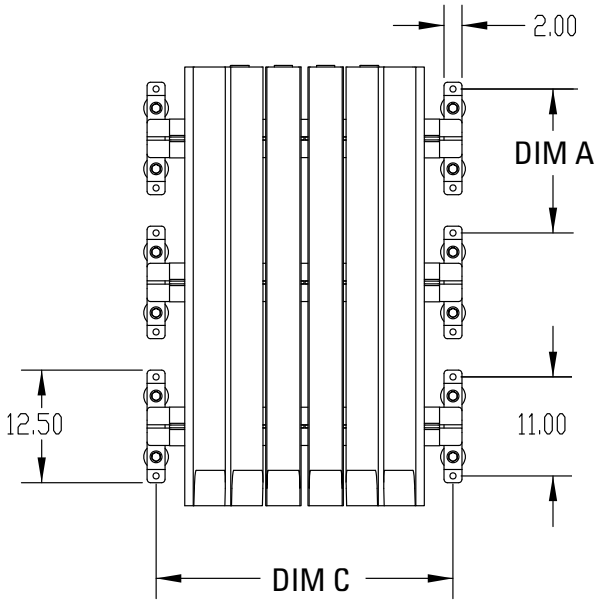

Bed Length	Dim A	Dim B	Bed Width	Dim C	Dim D
4' (1.2M)	16" (400mm)	48.75" (1219mm)	24 (600mm)	33 (835mm)	9 (225)
			30 (750mm)	39 (975mm)	9 (225)
			36 (900mm)	45 (1125mm)	9 (225)
			42 (1050mm)	51 (1275mm)	9 (225)
			48 (1200mm)	57 (1425mm)	9 (225)
			54 (1350mm)	63 (1575mm)	9.25 (231mm)
			60 (1500mm)	69 (1725mm)	9.25 (231mm)
			72 (1800mm)	81 (2025mm)	9.5 (238mm)

Bed Length	Dim A	Dim B	Bed Width	Dim C	Dim D
5' (1.5")	22 (550mm)	59.06 (1477mm)	24 (600mm)	33 (835mm)	9 (225)
			30 (750mm)	39 (975mm)	9 (225)
			36 (900mm)	45 (1125mm)	9 (225)
			42 (1050mm)	51 (1275mm)	9 (225)
			48 (1200mm)	57 (1425mm)	9 (225)
			54 (1350mm)	63 (1575mm)	9.25 (231mm)
			60 (1500mm)	69 (1725mm)	9.25 (231mm)
			72 (1800mm)	81 (2025mm)	9.5 (238mm)

# Section 8 - Specifications and CAD Drawings

## 8.2 CAD Drawing - DRX750 35° Trough

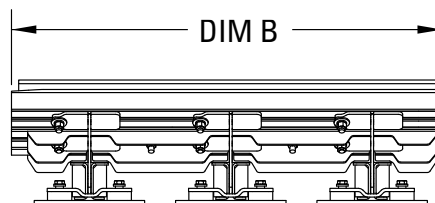
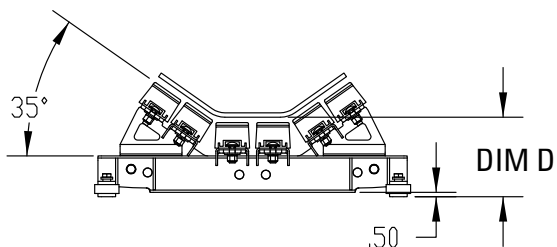
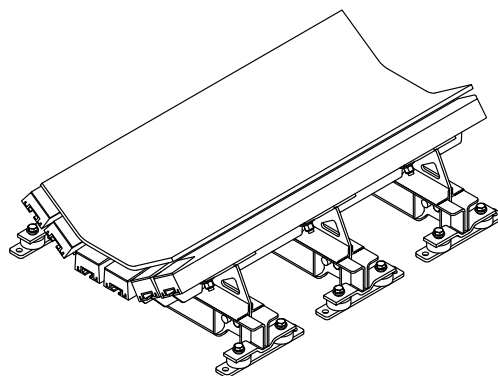
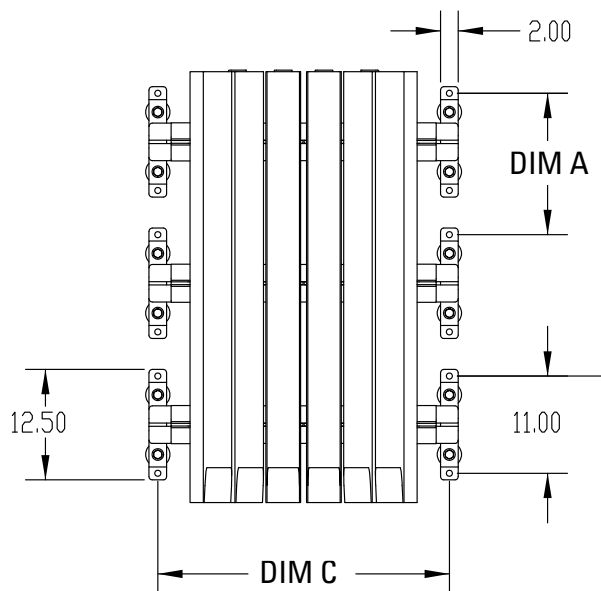

Bed Length	Dim A	Dim B	Bed Width	Dim C	Dim D
4' (1.2M)	16" (400mm)	48.75" (1219mm)	24 (600mm)	33 (835mm)	9 (225)
			30 (750mm)	39 (975mm)	9 (225)
			36 (900mm)	45 (1125mm)	9 (225)
			42 (1050mm)	51 (1275mm)	9 (225)
			48 (1200mm)	57 (1425mm)	9 (225)
			54 (1350mm)	63 (1575mm)	9.25 (231mm)
			60 (1500mm)	69 (1725mm)	9.25 (231mm)
			72 (1800mm)	81 (2025mm)	9.5 (238mm)

Bed Length	Dim A	Dim B	Bed Width	Dim C	Dim D
5' (1.5")	22 (550mm)	59.06 (1477mm)	24 (600mm)	33 (835mm)	9 (225)
			30 (750mm)	39 (975mm)	9 (225)
			36 (900mm)	45 (1125mm)	9 (225)
			42 (1050mm)	51 (1275mm)	9 (225)
			48 (1200mm)	57 (1425mm)	9 (225)
			54 (1350mm)	63 (1575mm)	9.25 (231mm)
			60 (1500mm)	69 (1725mm)	9.25 (231mm)
			72 (1800mm)	81 (2025mm)	9.5 (238mm)

# Section 8 - Specifications and CAD Drawings

## 8.2 CAD Drawing - DRX1500, 20° Trough

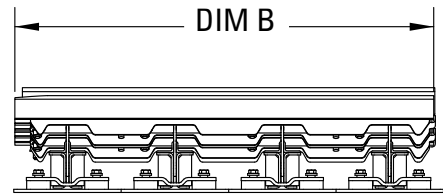
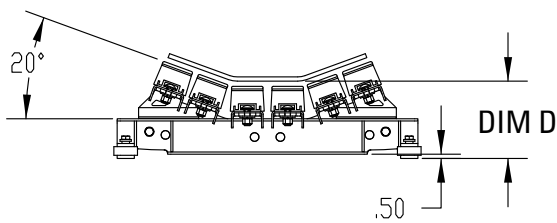
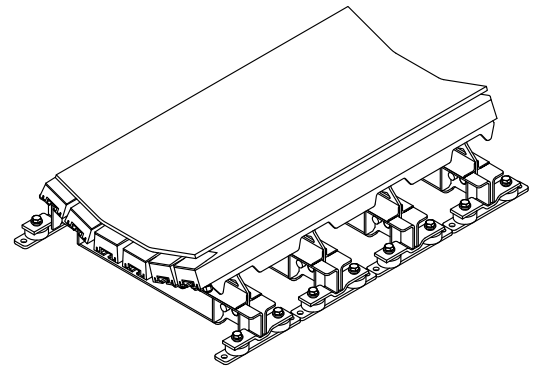
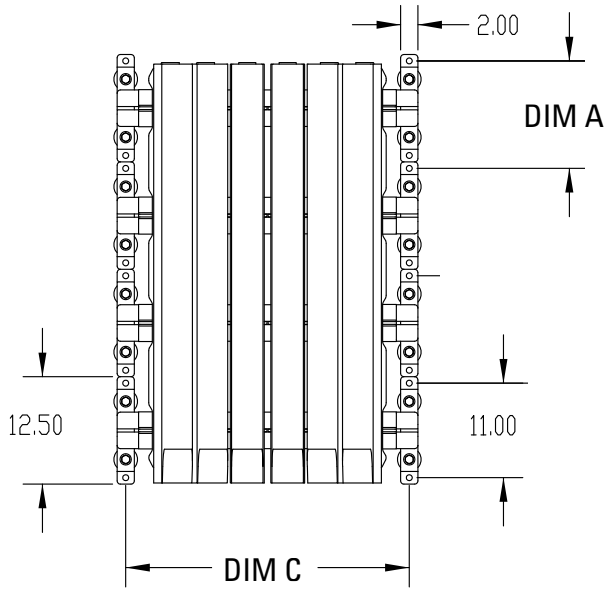

Bed Length	Dim A	Dim B	Bed Width	Dim C	Dim D
4' (1.2M)	12.5" (313mm)	48.75" (1219mm)	24 (600mm)	33 (835mm)	9 (225)
			30 (750mm)	39 (975mm)	9 (225)
			36 (900mm)	45 (1125mm)	9 (225)
			42 (1050mm)	51 (1275mm)	9 (225)
			48 (1200mm)	57 (1425mm)	9 (225)
			54 (1350mm)	63 (1575mm)	9.25 (231mm)
			60 (1500mm)	69 (1725mm)	9.25 (231mm)
			72 (1800mm)	81 (2025mm)	9.5 (238mm)

Bed Length	Dim A	Dim B	Bed Width	Dim C	Dim D
5' (1.5")	16 (400mm)	59.06 (1477mm)	24 (600mm)	33 (835mm)	9 (225)
			30 (750mm)	39 (975mm)	9 (225)
			36 (900mm)	45 (1125mm)	9 (225)
			42 (1050mm)	51 (1275mm)	9 (225)
			48 (1200mm)	57 (1425mm)	9 (225)
			54 (1350mm)	63 (1575mm)	9.25 (231mm)
			60 (1500mm)	69 (1725mm)	9.25 (231mm)
			72 (1800mm)	81 (2025mm)	9.5 (238mm)

# Section 8 - Specifications and CAD Drawings

## 8.2 CAD Drawing - DRX1500 35° Trough

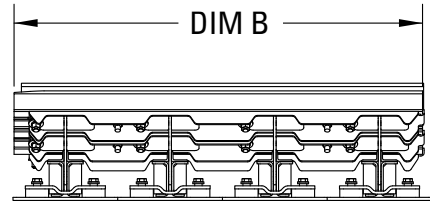
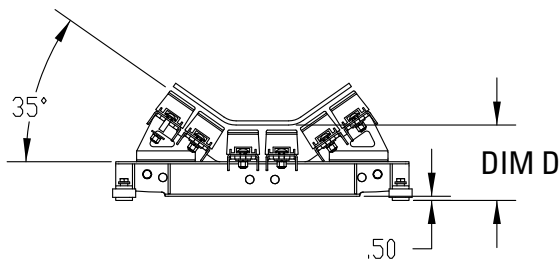
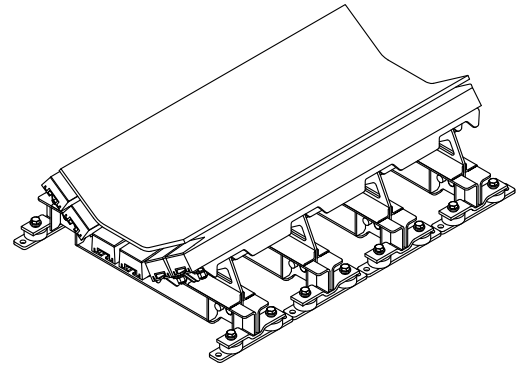
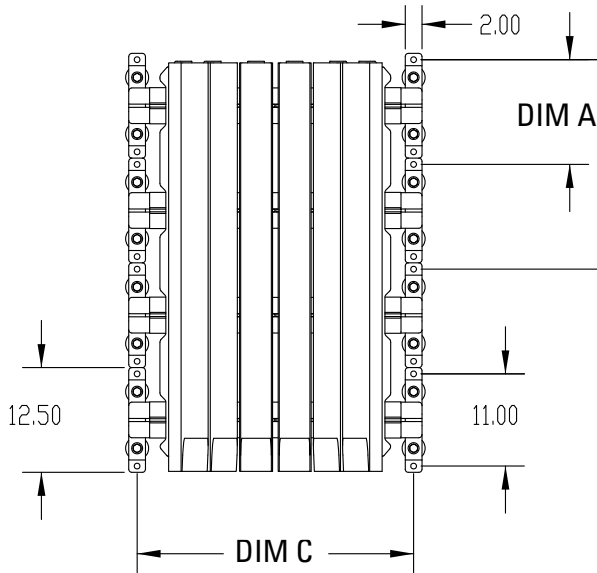

Bed Length	Dim A	Dim B	Bed Width	Dim C	Dim D
4' (1.2M)	12.5" (313mm)	48.75" (1219mm)	24 (600mm)	33 (835mm)	9 (225)
			30 (750mm)	39 (975mm)	9 (225)
			36 (900mm)	45 (1125mm)	9 (225)
			42 (1050mm)	51 (1275mm)	9 (225)
			48 (1200mm)	57 (1425mm)	9 (225)
			54 (1350mm)	63 (1575mm)	9.25 (231mm)
			60 (1500mm)	69 (1725mm)	9.25 (231mm)
			72 (1800mm)	81 (2025mm)	9.5 (238mm)

Bed Length	Dim A	Dim B	Bed Width	Dim C	Dim D
5' (1.5")	16 (400mm)	59.06 (1477mm)	24 (600mm)	33 (835mm)	9 (225)
			30 (750mm)	39 (975mm)	9 (225)
			36 (900mm)	45 (1125mm)	9 (225)
			42 (1050mm)	51 (1275mm)	9 (225)
			48 (1200mm)	57 (1425mm)	9 (225)
			54 (1350mm)	63 (1575mm)	9.25 (231mm)
			60 (1500mm)	69 (1725mm)	9.25 (231mm)
			72 (1800mm)	81 (2025mm)	9.5 (238mm)

# Section 9 - Replacement Parts

## 9.1 Replacement Parts List

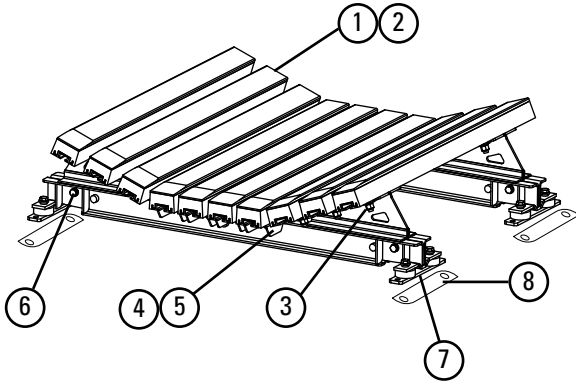

DRX200 Replacement Parts				
Ref	Description	Ordering Number	Item Code	Wt. Kgs.
1	Impact Bar, 1200mm	IB4	76926	7.7
2	Impact Bar, 1500mm	IB5	76927	9.6
3	Impact Bar Bolt Kit incl. (1) ea 19mm carriage bolt, square washer, flat washer, lock washer, Nylock nut	R1BBK	81250	.2
4	Impact Bar Support -L 1200mm incl. (1) ea bar support, carriage bolt, square washer, lock washer, Nylock nut	IBS-L1200	81245	7.6
5	Impact Bar Support -L 1500mm incl. (1) ea bar support, carriage bolt, square washer, lock washer, Nylock nut	IBS-L1500	81246	9.5
6	Sliding Support Arm Bolt Kit incl. (2) 50mm bolts, (2) lock washers, (2) Nylock nuts	MISABK-LMH	81247	.9
7	Isolation Mount Kit	MIMK	81248	1.7
8	DRX200 Shim Kit (incl. 4 shims)	MSHIM-KITL	81249	6.2

Lead time: 1 working day

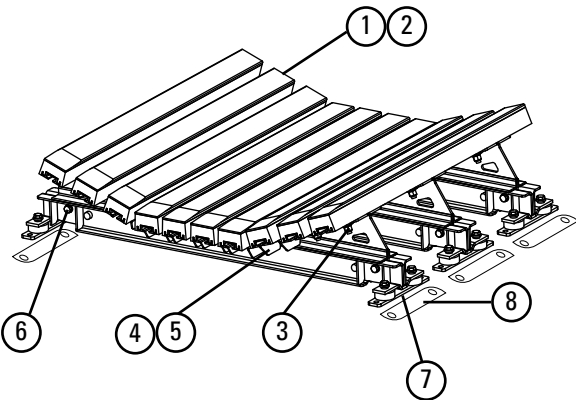

DRX750 Replacement Parts				
Ref	Description	Ordering Number	Item Code	Wt. Kgs.
1	Impact Bar, 1200mm	IB4	76926	7.7
2	Impact Bar, 1500mm	IB5	76927	9.6
3	Impact Bar Bolt Kit (incl. (1) ea 19mm carriage bolt, square washer, flat washer, lock washer, Nylock nut)	R1BBK	81250	.2
4	Impact Bar Support -M 1200mm (incl. (1) bar support, (2) ea carriage bolt, square washer, lock washer, Nylock nut)	IBS-M1200	81412	7.6
5	Impact Bar Support -M 1500mm (incl. (1) bar support, (2) ea carriage bolt, square washer, lock washer, Nylock nut)	IBS-M1500	81413	9.5
6	Sliding Support Arm Bolt Kit (incl. (2) 50mm bolts, (2) lock washers, (2) Nylock nuts)	MISABK-LMH	81247	.9
7	Isolation Mount Kit	MIMK	81248	1.7
8	DRX750 Shim Kit (incl. 6 shims)	MSHIM-KITM	81414	6.2

Lead time: 1 working day

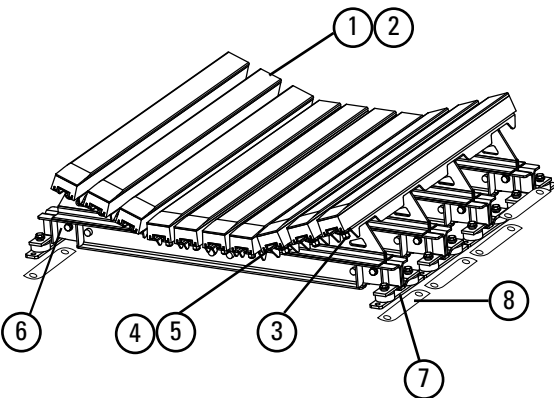

DRX1500 Replacement Parts				
Ref	Description	Ordering Number	Item Code	Wt. Kgs.
1	Impact Bar, 1200mm	IB4	76926	7.7
2	Impact Bar, 1500mm	IB5	76927	9.6
3	Impact Bar Bolt Kit incl. (1) ea 19mm carriage bolt, square washer, flat washer, lock washer, Nylock nut	R1BBK	81250	.2
4	Impact Bar Support -H 4' incl. (1) bar support, (2) ea carriage bolt, square washer, lock washer, Nylock nut	IBS-H1200	81415	7.5
5	Impact Bar Support -H 5' incl. (1) bar support, (2) ea carriage bolt, square washer, lock washer, Nylock nut	IBS-H1500	81416	9.5
6	Sliding Support Arm Bolt Kit incl. (2) 50mm bolts, (2) lock washers, (2) Nylock nuts	MISABK-LMH	81247	.9
7	Isolation Mount Kit	MIMK	81248	1.7
8	DRX1500 Shim Kit (incl. 8 shims)	MSHIM-KITH	81417	12.3

Lead time: 1 working day

# Section 9 - Replacement Parts

## 9.2 Optional Replacement Parts

### Impact Bar with 1" (25mm) UHMW

For impact beds that have heavy abrasive wear on the impact bars.

Impact Bar Bolt Kit for Other OEM Impact Beds*			
Description	Ordering Number	Item Code	Wt. Kgs.
1200mm Impact Bar with 25mm UHMW	IB4-1U	76965	7.7
1500mm Impact Bar with 25mm UHMW	IB5-1U	76966	9.6

\*Kit includes 1 ea. bolt, square washer, flat washer and nut.  
Lead time: 1 working day

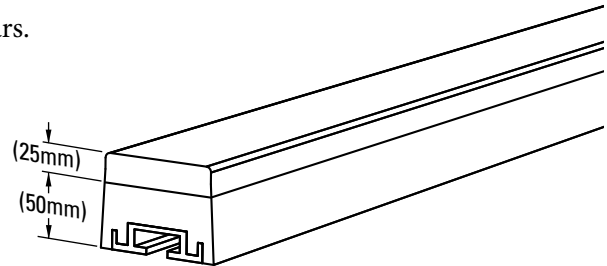

Impact Bar with  
25mm UHMW  
Cover

### Optional Impact Bar Bolt Kit

1/2" (13mm) carriage bolt, square washer, flat washer and Nylock nut to mount DRX Impact Bars on other OEM beds that use 13mm T-bolts.

Impact Bar Bolt Kit for Other OEM Impact Beds*			
Description	Ordering Number	Item Code	Wt. Kgs.
Optional Impact Bar Bolt Kit	RIBBK	81250	.2

\*Kit includes 1 ea. bolt, square washer, flat washer and nut.  
Lead time: 1 working day

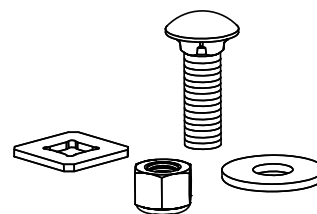

Optional Impact  
Bar Bolt Kit

## Section 10 – Other Flexco Conveyor Products

---

Flexco provides many conveyor products that help your conveyors to run more efficiently and safely. These components solve typical conveyor problems and improve productivity. Here is a quick overview on just a few of them:

### EZP1 Primary Cleaner



- Patented ConShear™ blade renews its cleaning edge as it wears
- Visual Tension Check™ for optimal blade tensioning and simple retensioning
- Quick and easy one-pin blade replacement Material Path Option™ for optimal cleaning and reduced maintenance

### Flex-Lok™ Skirt Clamps

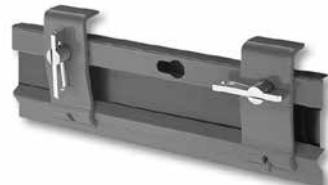

- Eliminates transfer zone spillage
- Interlocking design for easy installation and one person maintenance
- Unique wedge pin holds rubber securely in place and is easy to adjust
- Available in various models and in stainless steel

### EZS2 Secondary Cleaner



- Long-wearing tungsten carbide blades for superior cleaning efficiency
- Patented FormFlex™ cushions independently tension each blade to the belt for consistent, constant cleaning power
- Easy to install, simple to service
- Works with Flexco mechanical belt splices

### PT Max™ Belt Trainer



- Patented “pivot & tilt” design for superior training action
- Dual sensor rollers on each side to minimize belt damage
- Pivot point guaranteed not to seize or freeze up
- Available for topside and return side belts

### Flexco Specialty Belt Cleaners



- “Limited space” cleaners for tight conveyor applications
- High Temp cleaners for severe, high heat applications
- A rubber fingered cleaner for chevron and raised rib belts
- Multiple cleaner styles in stainless steel for corrosive applications

### Belt Ploughs



- A belt cleaner for the tail pulley
- Exclusive blade design quickly spirals debris off the belt
- Economical and easy to service
- Available in vee or diagonal models

## **The Flexco Vision**

To become the leader in maximising  
belt conveyor productivity for our customers worldwide  
through superior service and innovation.

Flexco (Aust.) Pty. Ltd • 10 Solent Circuit • Baulkham Hills NSW 2153 • Australia  
Tel: 612-8818-2000 • Fax: 612-8824-6333 • E-mail: [sales@flexco.com.au](mailto:sales@flexco.com.au) • Web: [www.flexco.com](http://www.flexco.com)

Australia: 61-2-8818-2000 • Chile: 56-2-8967870 • China: 86-21-33528388  
England: 44-1274-600-942 • Germany: 49-7428-9406-0 • India: 91-44-4354-2091  
Mexico: 52-55-5674-5326 • Singapore: 65-6281-7278 • South Africa: 27-11-608-4180 • USA: 1-630-971-0150

©2013 Flexible Steel Lacing Company. 03/13. X3172

